

Pressure range up to: 6000 psi (413 bar)

Max Allowable Temperature

- 450 °F (232°C) max with PTFE stem packing
- 1200 °F (648°C) max with Graphite stem packing and 316SS, Hastelloy C-276, Super Duplex

Stem Threads Are Protected From Process Media (Not-wetted)

- Manifold bodies : 316/316L Stainless Steel, Monel Alloy 400, Hastelloy C-276, Super Duplex available
- Bonnet locking pin to prevents bonnet loosening due to vibration.
- All Valves 100% factory tested.



GV Series Gauge and Root Valves



M Series Instrument Manifolds 5-Valve Manifolds



M Series Instrument Manifolds 2-Valve Manifolds



M Series Instrument Manifolds 3-Valve Manifolds



VGVTVMF(Male to Female with Vent Port)

I : PTFE Packing
G: Graphite Packing

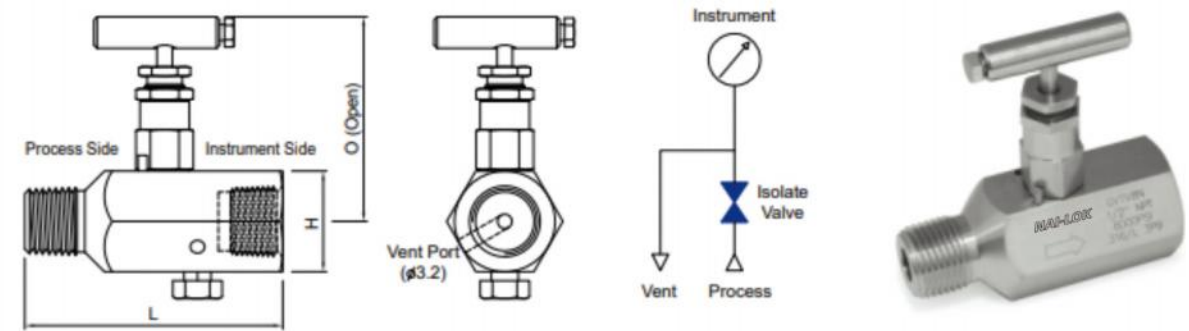

| Part No. | End Connection | | Dimensions in.(mm) | | |
|------------------|----------------|-----------------|--------------------|------------|------------|
| | Process | Instrument | L | O (Open) | H(Hex) |
| VGVTVMF4N-VP | 1/4" NPT Male | 1/4" NPT Female | 2.94(75.0) | 2.68(68.0) | 1.18(30.0) |
| VGVTVMF8N-VP | 1/2" NPT Male | 1/2" NPT Female | 3.50(89.0) | 2.72(69.0) | 1.26(32.0) |
| VGVTVMF12N12N-VP | 3/4" NPT Male | 3/4" NPT Female | 3.50(89.0) | 2.72(69.0) | 1.26(32.0) |
| VGVTVMF12N-VP | 3/4" NPT Male | 3/4" NPT Female | 3.50(89.0) | 2.83(72.0) | 1.50(38.0) |

VGVTVF(Female to Female with Vent Port)

I : PTFE Packing
G: Graphite Packing

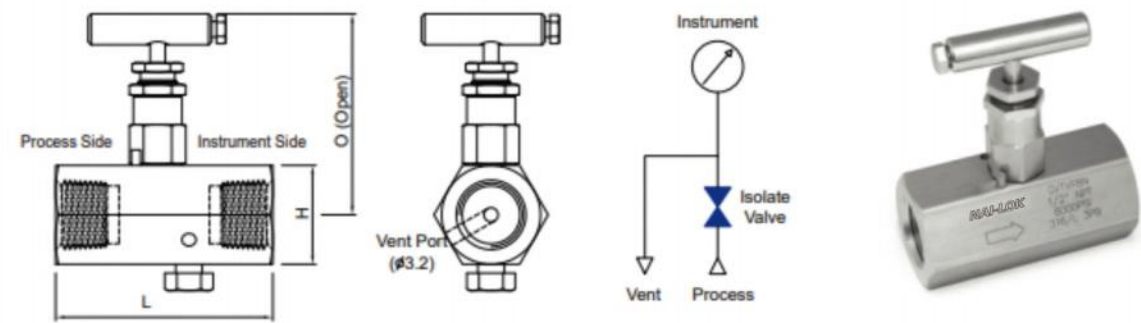

| Part No. | End Connection | | Dimensions in.(mm) | | |
|--------------|-----------------|------------|--------------------|------------|------------|
| | Process | Instrument | L | O (Open) | H(Hex) |
| VGVTVF4N-VP | 1/4" NPT Female | | 2.25(57.5) | 2.68(68.0) | 1.18(30.0) |
| VGVTVF8N-VP | 1/2" NPT Female | | 2.81(71.5) | 2.72(69.0) | 1.26(32.0) |
| VGVTVF12N-VP | 3/4" NPT Female | | 2.81(71.5) | 2.83(72.0) | 1.50(38.0) |

All dimensions are in millimeters (inches) reference only, subject to change.

VG2TV-MF(Male to Female with 1/4" NPT Vent Port)

I : PTFE Packing
G: Graphite Packing

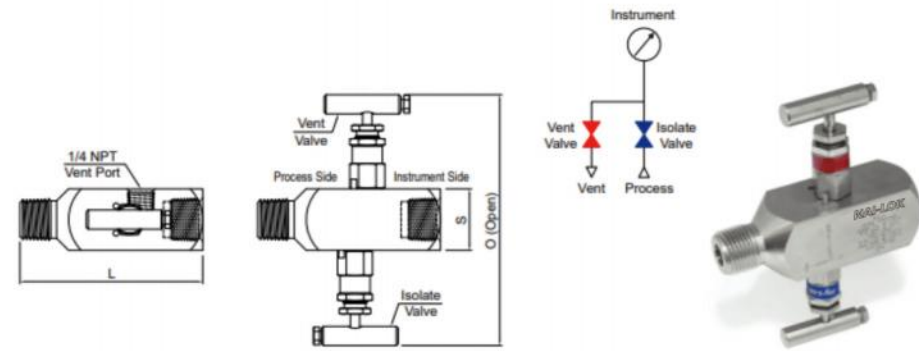

| Part | End Connection | | Dimensions in.(mm) | | |
|---------------|------------------|-----------------|--------------------|-------------|------------|
| | Process | Instrument | L | O (Open) | S(Square) |
| VG2TV-MF4N | 1/4 in. NPT Male | 1/4" NPT Female | 3.19(81.0) | 5.35(136.0) | 1.18(30.0) |
| VG2TV-MF8N | 1/2 in. NPT Male | 1/2" NPT Female | 3.75(95.5) | 5.43(138.0) | 1.26(32.0) |
| VG2TV-MF12N8N | 3/4 in. NPT Male | 1/2" NPT Female | 3.75(95.5) | 5.43(138.0) | 1.26(32.0) |
| VG2TV-MF12N | 3/4 in. NPT Male | 3/4" NPT Female | 3.75(95.5) | 5.67(144.0) | 1.50(38.0) |

VG2TV-F(Female to Female with 1/4" NPT Vent Port)

I : PTFE Packing
G: Graphite Packing

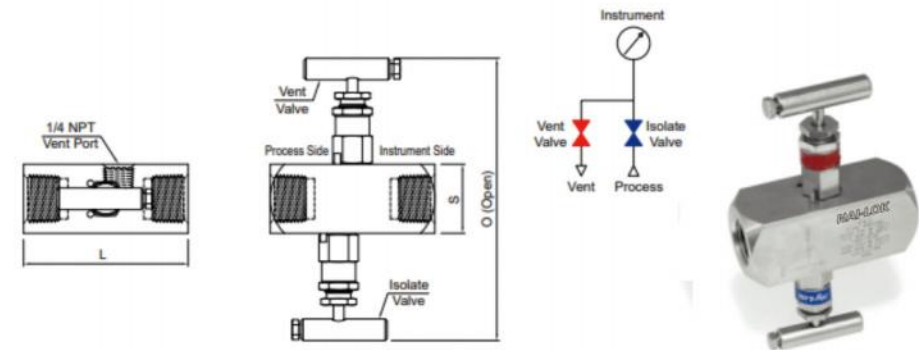

| Part | End Connection | | Dimensions in.(mm) | | |
|--------------|-----------------|-----------------|--------------------|-------------|------------|
| | Process | Instrument | L | O (Open) | S(Square) |
| VG2TV-F4N | 1/4" NPT Female | | 2.50(63.5) | 5.36(136.0) | 1.18(30.0) |
| VG2TV-F8N | 1/2" NPT Female | | 3.06(78.0) | 5.43(138.0) | 1.26(32.0) |
| VG2TV-F12N8N | 3/4" NPT Female | 1/2" NPT Female | 3.06(78.0) | 5.67(144.0) | 1.50(38.0) |
| VG2TV-F12N | 3/4" NPT Female | | 3.06(78.0) | 5.67(144.0) | 1.50(38.0) |

All dimensions are in millimeters (inches) reference only, subject to change.

VG2TV-FM(Female to Male with 1/4" NPT Vent Port)

I : PTFE Packing
G: Graphite Packing

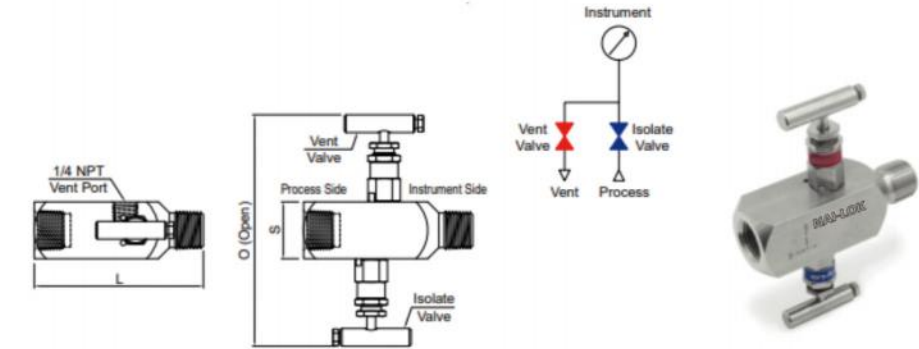

| Part No. | End Connection | | Dimensions in.(mm) | | |
|---------------|-----------------|---------------|--------------------|-------------|------------|
| | Process | Instrument | L | O (Open) | S(Square) |
| VG2TV-FM4N | 1/4" NPT Female | 1/4" NPT Male | 3.19(81.0) | 5.36(136.0) | 1.18(30.0) |
| VG2TV-FM8N | 1/2" NPT Female | 1/2" NPT Male | 3.75(95.5) | 5.43(138.0) | 1.26(32.0) |
| VG2TV-FM12N8N | 3/4" NPT Female | 1/2" NPT Male | 3.75(95.5) | 5.67(144.0) | 1.50(38.0) |
| VG2TV-FM12N | 3/4" NPT Female | 3/4" NPT Male | 3.75(95.5) | 5.67(144.0) | 1.50(38.0) |

VGRVTVMF(Male to Female with Multi Port)

I : PTFE Packing
G: Graphite Packing

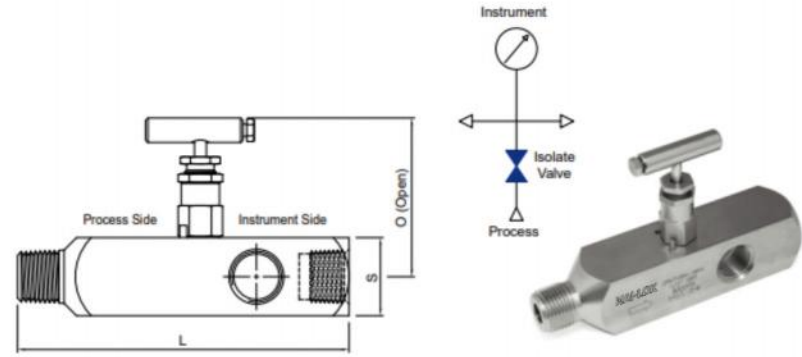

| Part No. | End Connection | | Dimensions in.(mm) | | |
|---------------|-----------------|-----------------|--------------------|------------|------------|
| | Process | Instrument | L | O (Open) | S(Square) |
| VGRVTVMF8N | 1/2" NPT Male | 1/2" NPT Female | 5.35(136.0) | 2.72(69.0) | 1.26(32.0) |
| VGRVTVMF12N8N | 3/4" NPT Male | 1/2" NPT Female | 5.35(136.0) | 2.72(69.0) | 1.26(32.0) |
| VGRVTVF8N | 1/2" NPT Female | | 5.35(136.0) | 2.72(69.0) | 1.26(32.0) |
| VGRVTVF12N8N | 3/4" NPT Female | 1/2" NPT Female | 4.02(102.0) | 2.78(70.5) | 1.38(35.0) |

All dimensions are in millimeters (inches) reference only, subject to change.

Ordering Information

| | | | | | | |
|---|---|---|--|---|--|---|
| <p>Valve Designator</p> <ul style="list-style-type: none"> • VGV: Gauge Valves • VGV2: Gauge 2-valves • VGRV: Root Valves • Example: VGVTVMF8N-S316 (Gauge Valve, PTFE Packing,Vee Tip, Male to Female End,1/2" NPT,316 Stainless Steel) | <p>Packing Designator</p> <ul style="list-style-type: none"> • T: PTFE(Standard) • G: Graphite(Optional) | <p>Type of End Designator Apply only for Gauge Valve</p> <ul style="list-style-type: none"> • F: Female to Female • MF: Male to Female • FM: Female to Male | <p>Vent Port Size Designator Apply only for Gauge Valve</p> <ul style="list-style-type: none"> • Nil: Without • 4N: 1/4" NPT <p>2nd Size Designator Apply only for Gauge 2-Valve</p> <ul style="list-style-type: none"> • Nil: Without • 4N : 1/4" NPT • 8N : 1/2" NPT • 12N :3/4" NPT | <p>1st Size Designator</p> <ul style="list-style-type: none"> • 4N: 1/4" NPT • 8N: 1/2" NPT • 12N: 3/4" NPT | <p>Option Designator</p> <ul style="list-style-type: none"> • SOG: NACE MR-01-75 • P: with Plug | <p>Body Material Designator</p> <ul style="list-style-type: none"> • S316: 316 Stainless Steel • 316L: 316L Stainless Steel • MONE: Monel Alloy 400 • C276 : Hastelloy® C-276 • F53: Super Duplex |
|---|---|---|--|---|--|---|

Remote Mount Manifolds (Female to Female)

Pressure Manifolds

VM2VTIV8N

0.8Kg (1.8 lb)
I: PTFE Packing
G: Graphite Packing

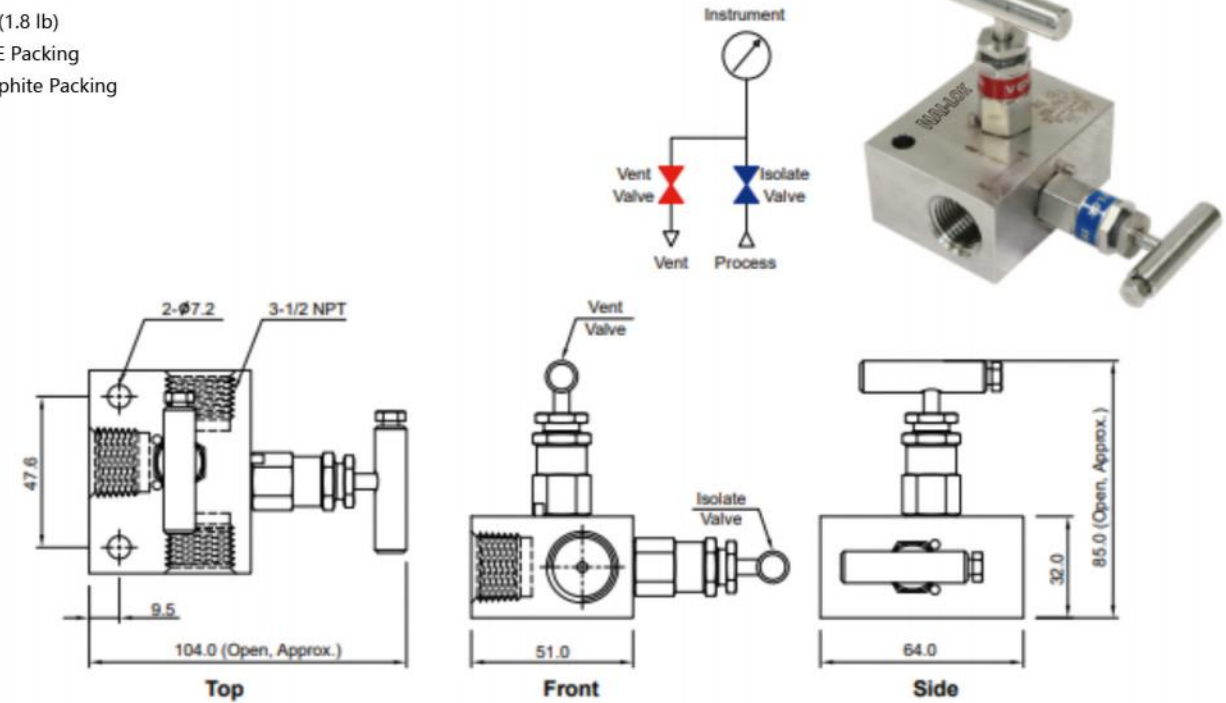

Remote Mount Manifolds/Vertical Vent (Female to Female)

Pressure Manifolds

VM2VWIV8N

0.9Kg (2.0 lb)
I: PTFE Packing
G: Graphite Packing

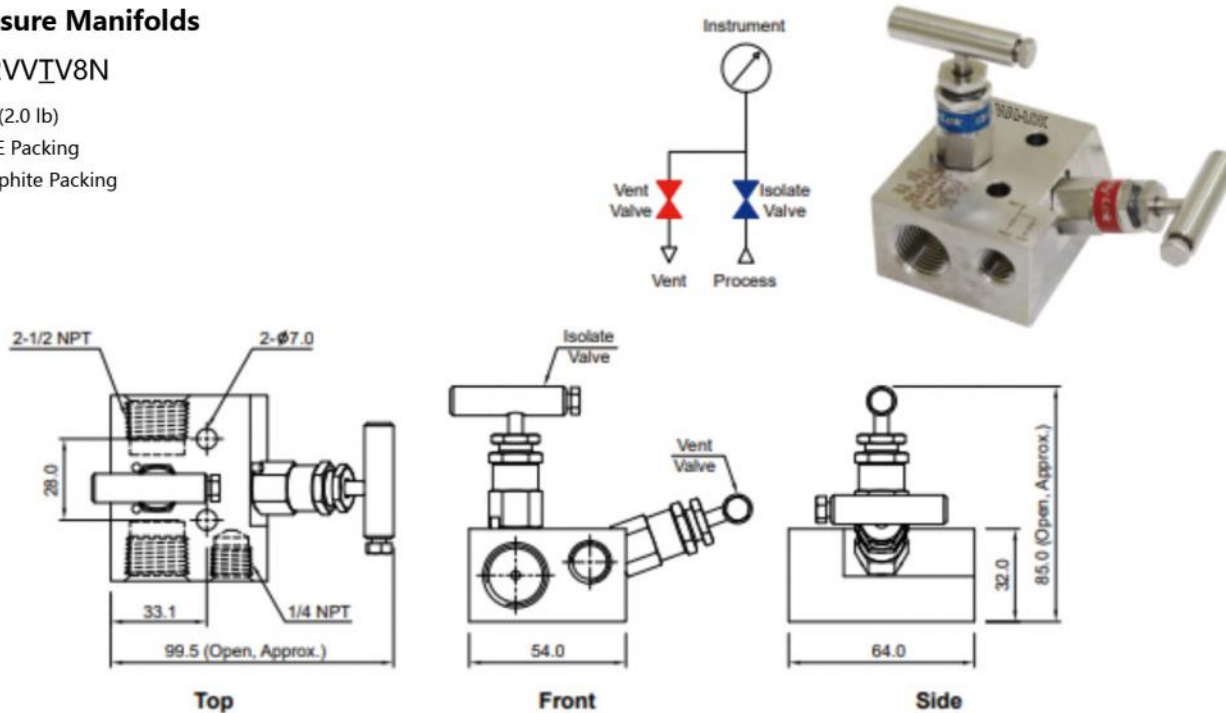

All dimensions are in millimeters (inches) reference only, subject to change.

Remote Mount Manifolds (Female to Female)

Differential Pressure Manifolds

VM3VIV8N

- 1.7Kg (3.7 lb)
- I: PTFE Packing
- G: Graphite Packing

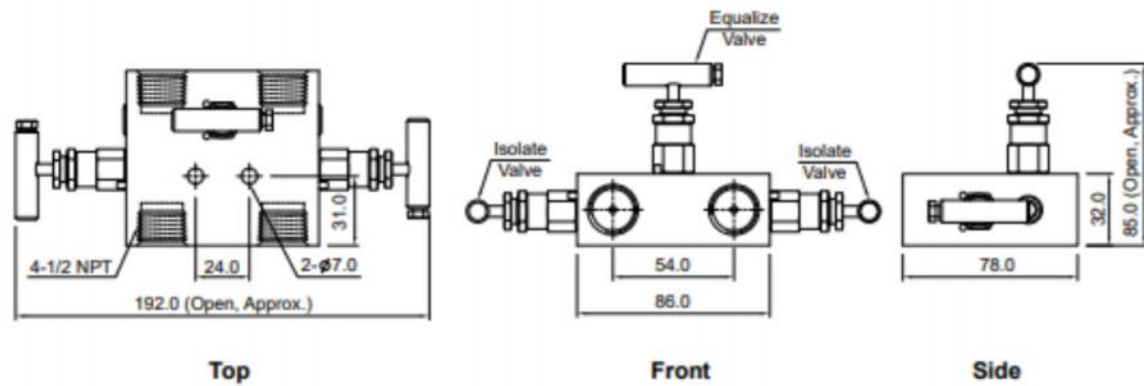
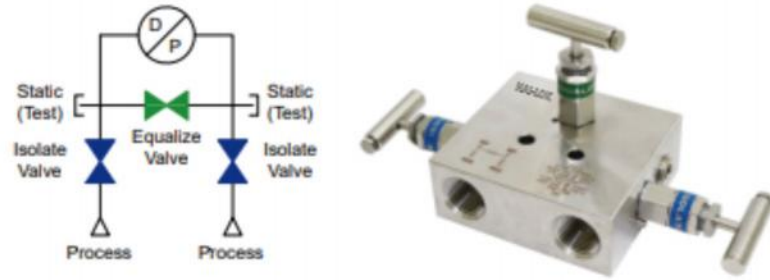

Direct Mount Manifolds/2-Flange (Female to Flange)

Differential Pressure Manifolds

VM3V2FIV

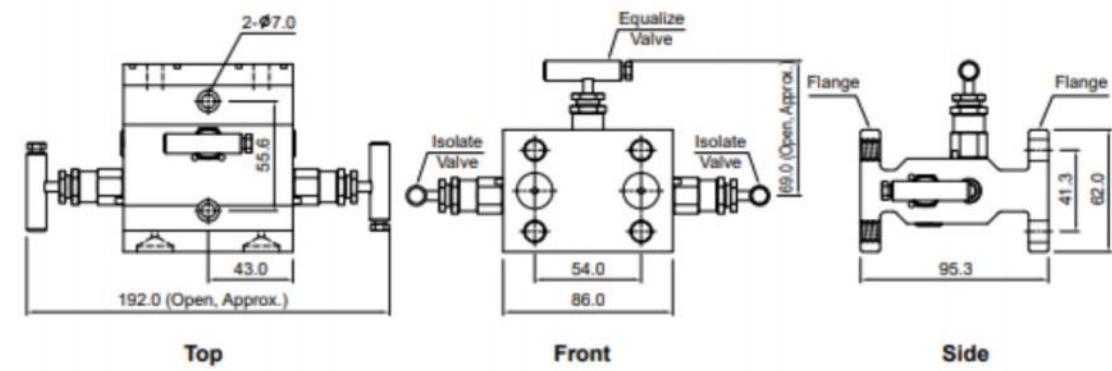
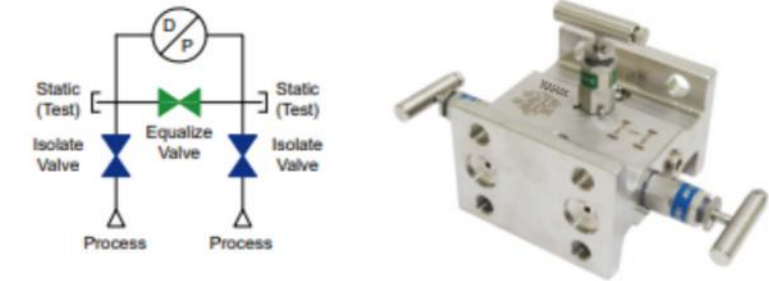

Direct Mount Manifolds/1- Flange (Female to Flange)

Differential Pressure Manifolds

VM3V1FIV8N

- 2.0Kg (4.4 lb)
- I: PTFE Packing
- G: Graphite Packing

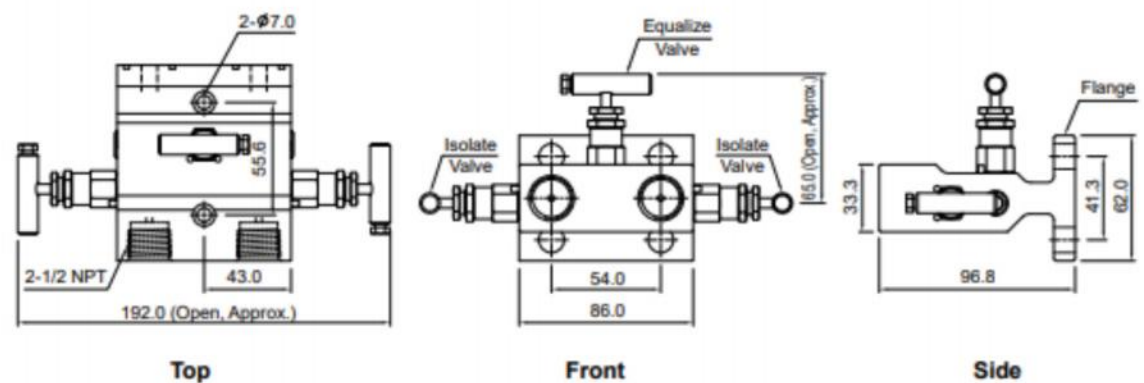

Direct Mount Manifolds(Female to Female)

Differential Pressure Manifolds

VM3VDMIV8N

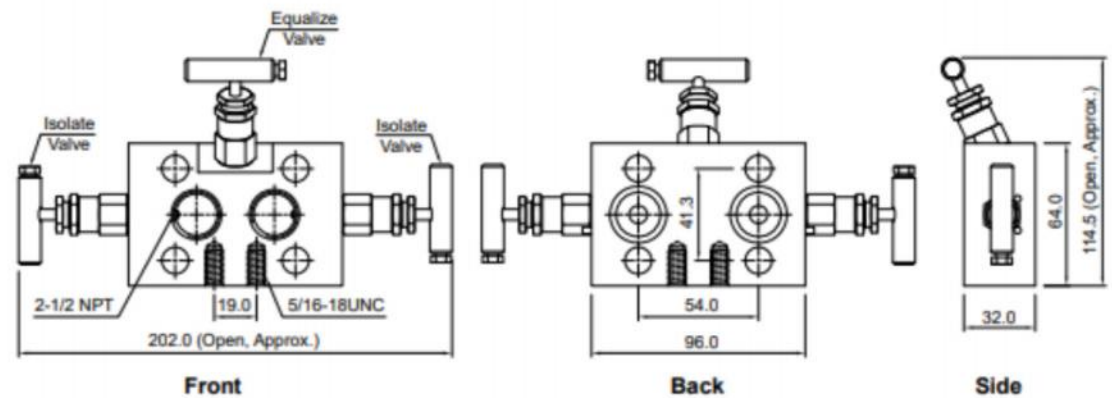

All dimensions are in millimeters (inches) reference only, subject to change.

All dimensions are in millimeters (inches) reference only, subject to change.

Double Direct Mount Manifolds (Flange to Flange)

Differential Pressure Manifolds

VM3V2DMIV

1.4Kg (3.1 lb)
I: PTFE Packing
G: Graphite Packing

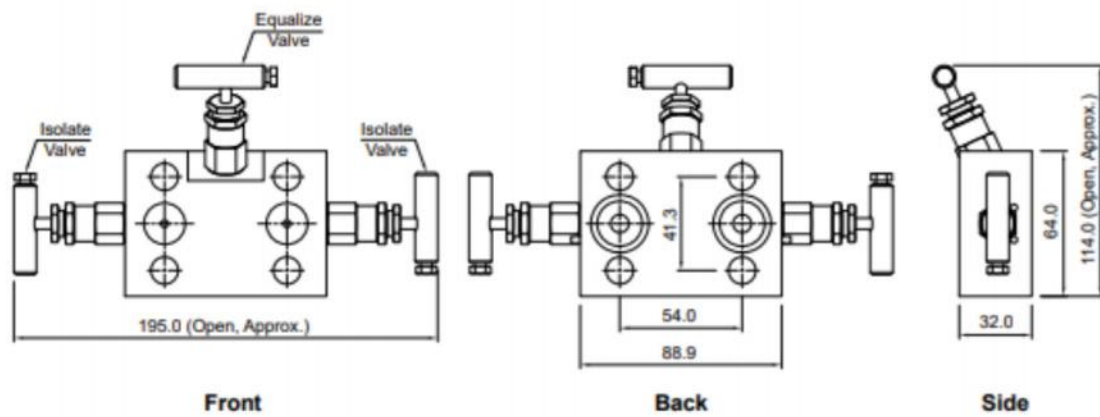

Direct Mount Manifolds/B Port (Female to Flange)

Differential Pressure Manifolds

VM3VDMBIV8N

1.8Kg (4.0 lb)
I: PTFE Packing
G: Graphite Packing

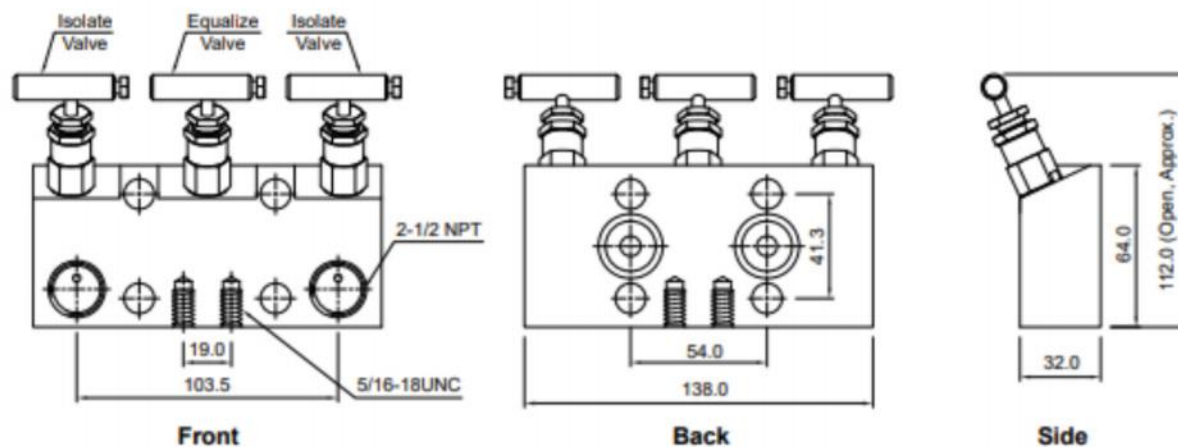
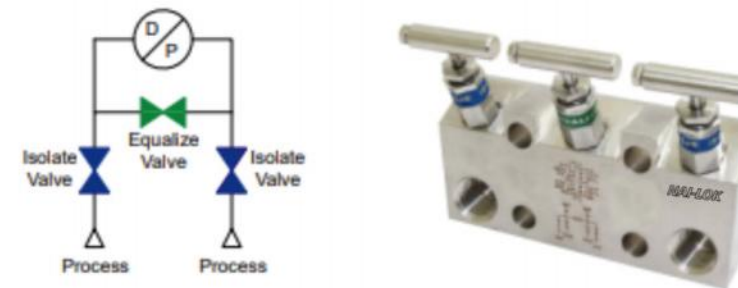

All dimensions are in millimeters (inches) reference only, subject to change.

Remote Mount Manifolds (Female to Female)

Differential Pressure Manifolds

VM5VIV8N

1.9Kg (4.2 lb)
I: PTFE Packing
G: Graphite Packing

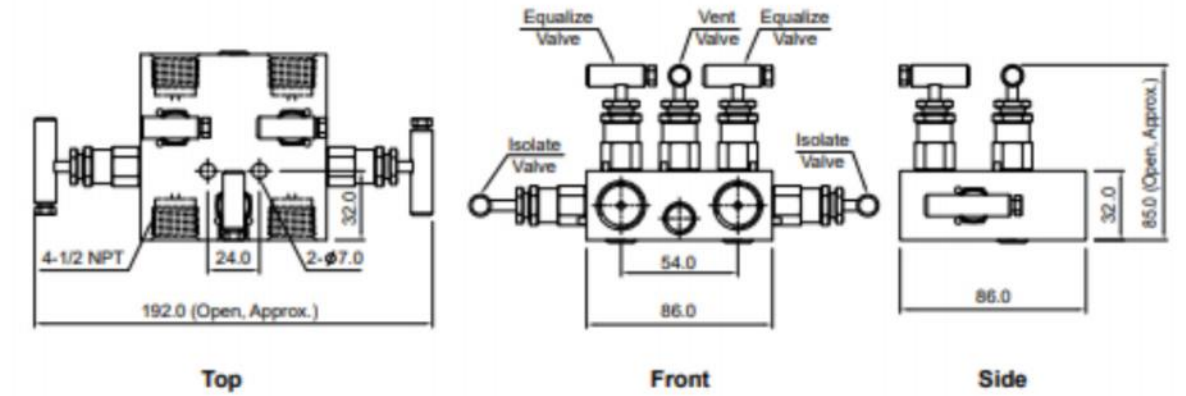
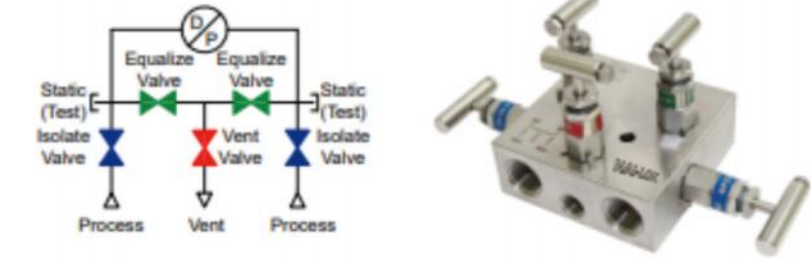

Direct Mount Manifolds/1-Flange (Female to Flange)

Differential Pressure Manifolds

VM5V1FIV8N

2.6Kg (5.7 lb)
I: PTFE Packing
G: Graphite Packing

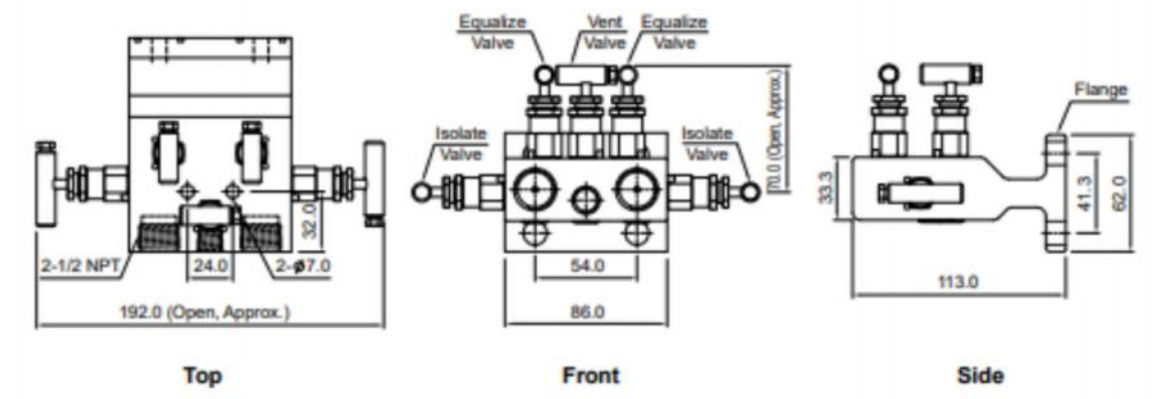
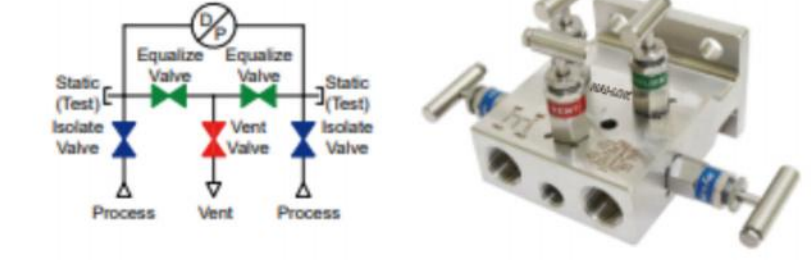

All dimensions are in millimeters (inches) reference only, subject to change.

Direct Mount Manifolds/2-Flange (Flange to Flange)

Differential Pressure Manifolds

VM5V2FIV

- 2.5Kg (5.5 lb)
- I: PTFE Packing
- G: Graphite Packing

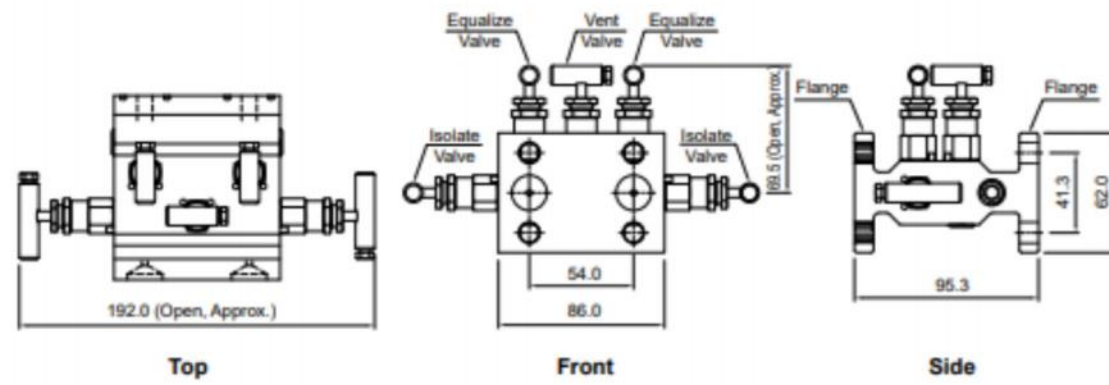
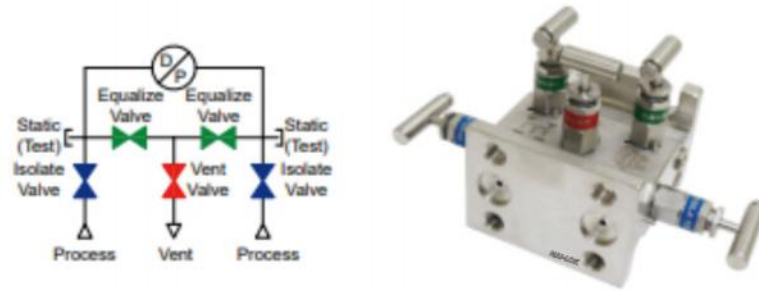

Direct Mount Manifolds/A Port (Female to Flange)

Differential Pressure Manifolds

VM5VDMATV8N

- 2.6Kg (5.8 lb)
- I: PTFE Packing
- G: Graphite Packing

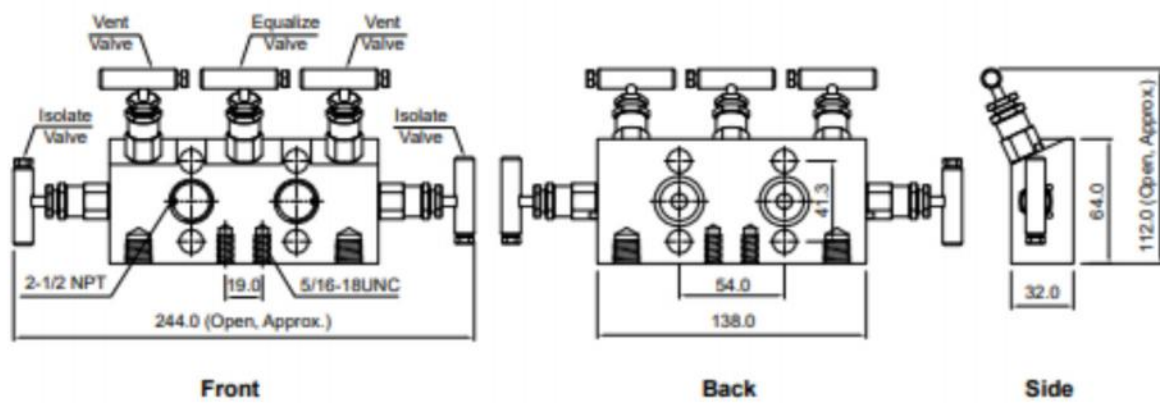

All dimensions are in millimeters (inches) reference only, subject to change.

Double Direct Mount Manifolds (Flange to Female)

Differential Pressure Manifolds

VM5V2DMIV

- 2.6Kg (5.8 lb)
- I: PTFE Packing
- G: Graphite Packing

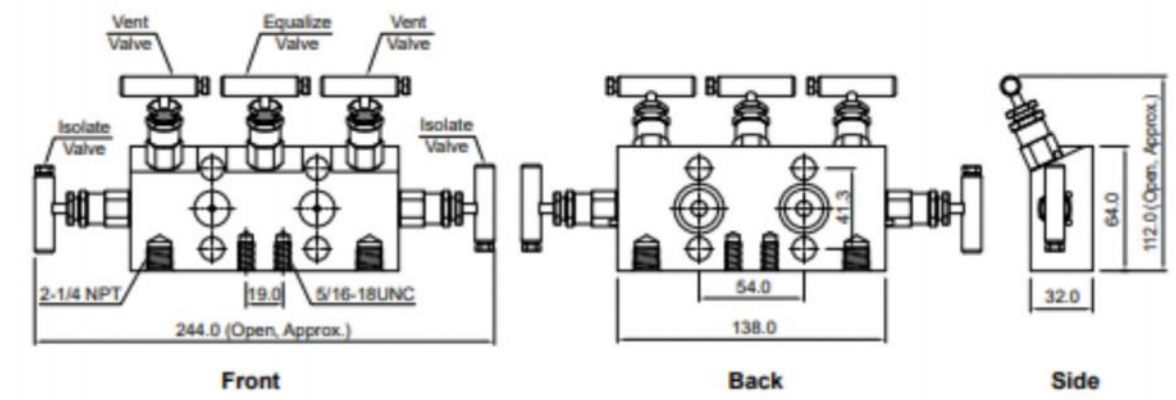
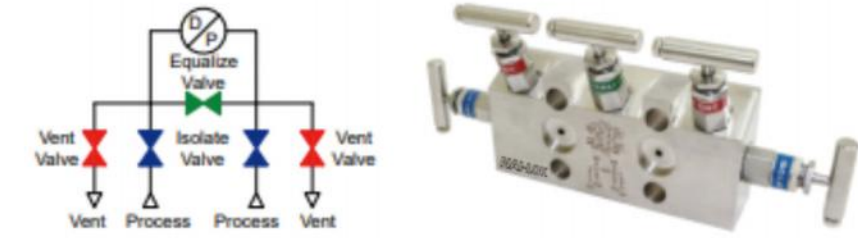

Direct Mount Manifolds/B Port (Female to Flange)

Differential Pressure Manifolds

VM5DMBIV8N

- 3.0Kg (6.62 lb)
- I: PTFE Packing
- G: Graphite Packing

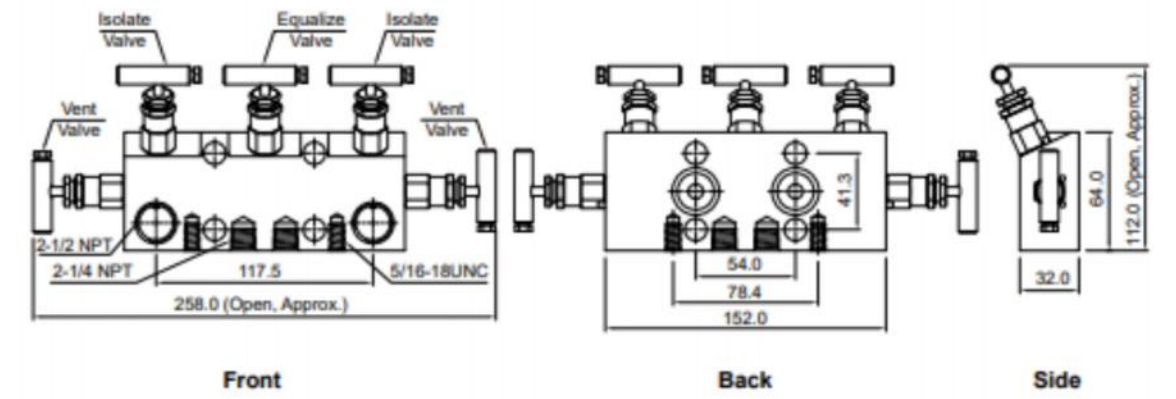
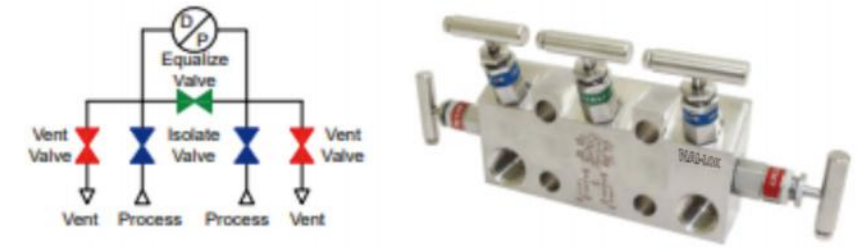

All dimensions are in millimeters (inches) reference only, subject to change.